



QH441 CONE CRUSHER ENGINEERING IN MOTION



Available with optional hanging screen system.



TECHNICAL SPECIFICATIONS

KEY SPECIFICATIONS	DATA
Crusher type	Sandvik CH440
Speed	327 rpm to 346 rpm
Feed opening	215 mm / 8 1/2"
CSS range	8 - 48 mm / 5/16" - 1 7/8"
Drive	PT Tech 14" Wet Clutch with PTO
Drive belts	10 SPC Single Belts

KEY SPECIFICATIONS	DATA
Power pack	
Engine type	Stage 3A / Tier 3 CAT C13 Acert or Stage 3B / Tier 4i CAT C13 Acert or Stage 4 / Tier4 Final CAT C13 Acert
Engine power	328 kW / 440 hp
Diesel tank size	990 litres / 262 USG
Hydraulic tank size	990 litres / 262 USG

Note. All weights and dimensions are for standard units only

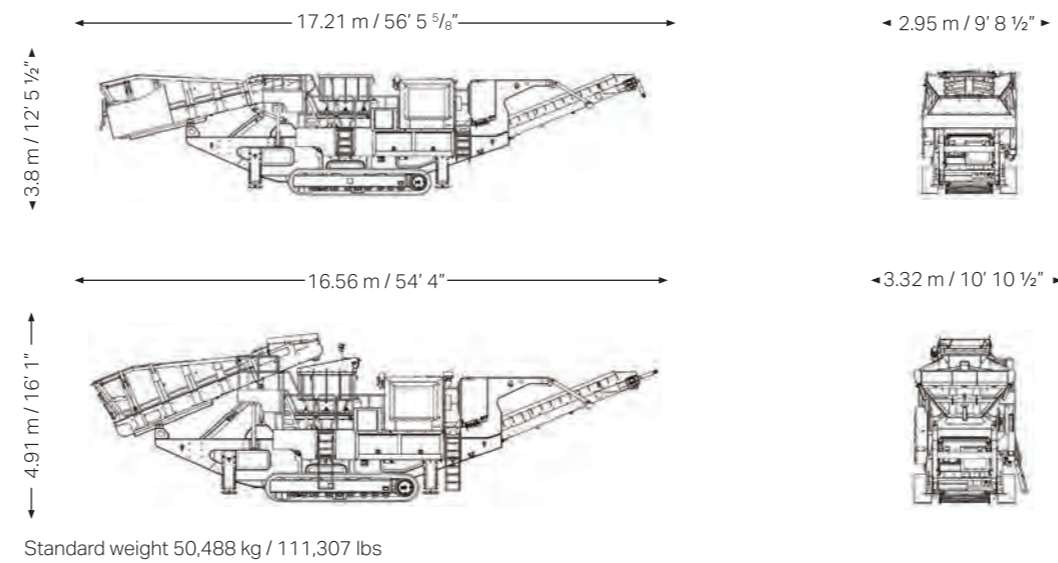

Featuring the proven, high performing Sandvik CH440 Hydrocone.

- 5 - CLP Liners are designed to keep maximum feed size into the cone throughout the wear life of the liners. All liner options fit in one top shell
- Constant liner opening results in constant production throughout liner life

- 6 - Longer crushing chamber due to top & bottom support which gives superior product shape in the chamber

- 7 - Bush arrangement has multiple settings to suit the required application
- Eccentric throw can be changed by simply turning the bush. The throw range is the most extensive in the market.

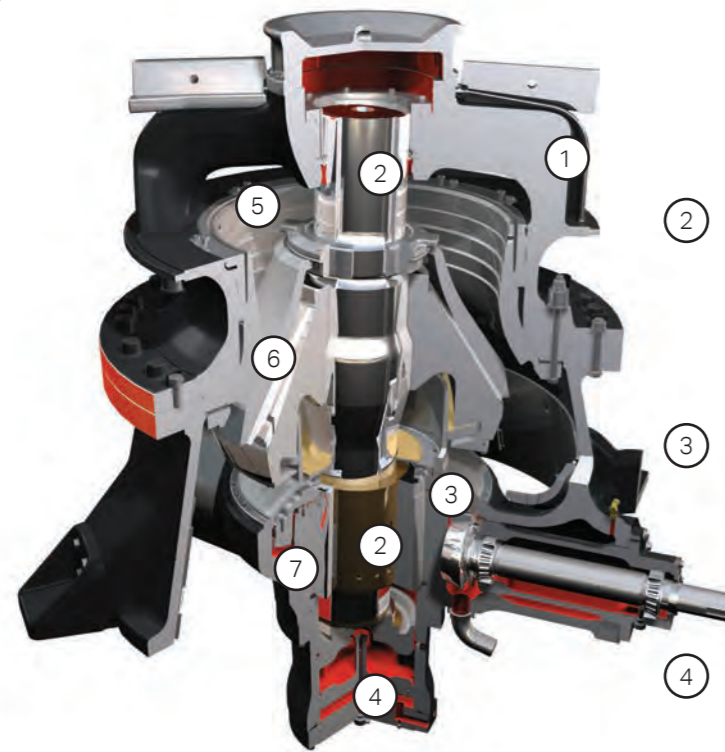

- 1 - Modular design with filler ring for ultimate flexibility
- Unique crusher design eliminates the need for anti-spin device on head

- 2 - Main Shaft is supported from both the Top and Bottom giving additional strength

- 3 - Helical drive gear arrangement for maximum durability and smooth, quiet operation

- 4 - Single piston design for gap setting and over load protection. CSS can also be adjusted whilst crushing



QH441 CONE CRUSHER ENGINEERING IN MOTION

KEY SPECIFICATIONS	DATA
Equipment	Sandvik CH440 Hydrocone
Maximum feed size	215 mm / 8 1/2"
Engine	C13 Acert 328 kW / 440 hp
Transport dimensions	17.21 m / 56' 5 3/8" (l) 2.95 m / 9' 8 1/2" (w) 3.8 m / 12' 5 1/2" (h)
Weight	50,488 kg / 111,307 lbs

VERSATILE SOLUTION

The QH441 is one of the most flexible and heavy duty cone crushers in the market today. Specifically aimed at large scale aggregates producers, the QH441 has been designed utilizing the latest technology to ensure uninterrupted productivity and minimal operator intervention.

Powered by a diesel engine with direct drive to ensure maximum power and fuel efficiency, it sets new standards in throughput, reduction ratios and gives excellent product shape. Available with a choice of six crushing chambers and a variety of bush settings, it stands as one of the most reliable, versatile and productive cone crushers in the market today.

STANDARD FEATURES INCLUDE:

- Emissions compliant 328 kW / 440 hp engine for powerful cost efficient performance
- Variable crusher speed via the engine to manipulate product gradation
- Equipped with a hydroset CSS regulation system that provides overload protection, optimizes production and keeps track of liner wear

- ② Feeder
- Automated variable speed 1200 mm / 47" wide feed conveyor to ensure maximum production, reduction and shape
 - Bridge Coil (up and over) metal detector fitted to the feed conveyor providing optimum stability and controlled detection

- ③ Cone
- Fitted with the proven CH440 Sandvik cone for strength and reliability
 - Equipped with Hydroset CSS regulation system for optimum production & protection
 - Choice of 6 concaves and a CSS range of 8 mm to 48 mm accepting a feed size of up to 215 mm / 8 1/2"
 - Various bush settings available to optimize product gradation and capacity
 - World renowned Constant Liner Performance system for optimum wear life of the liners
 - Hydraulic over load system for tramp material

- ④ Power pack
- 328 kW / 440 hp emissions compliant engine
 - Direct drive to ensure maximum power delivery
 - Variable crusher speed via the engine to manipulate product gradation
 - Easy access for service and maintenance
 - Ground level drainage points
 - Large capacity diesel tank 990 litre / 262 USG

- ⑤ Cooling fan
- Hydraulically driven cooling fan with auto reverse to back flush dust from radiator

- ① Hopper
- Wear resistant liner plates fitted as standard
 - Hydraulically raised and lowered for transport
 - Hydraulic folding hopper extensions for increased hopper capacity and rear loading (optional)

- ⑩ Chassis
- Heavy duty fabricated chassis on a tracked frame
 - Hydraulic legs for increased stability and servicing capabilities

- ⑨ Tracks
- 500 mm / 19 3/4" wide tracks driven by proportional umbilical control
 - Radio remote (optional)

STANDARD FEATURES



Camera and level sensor to ensure continuous feed



Bridge coil metal detector for controlled detection



Steel pipework for better heat dissipation



Easy access to the engine compartment

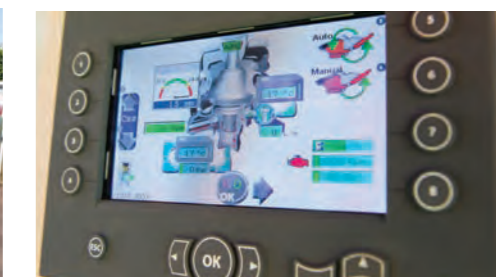

User friendly PLC control system with colour screen



Direct drive for maximum fuel efficiency



- ⑥ Main conveyor
- 1200 mm / 47" wide main conveyor with a discharge height of 3739 mm / 12' 3 1/4"
 - Dust suppression spray bars and canvas covers fitted as standard

- ⑧ Control system
- Highly efficient hydraulic and electric system provide ultimate system control
 - A full colour PLC screen with a simple operator interface combined with a level sensor above the crushing chamber and load control system allows for a fully automated crushing process

- ⑦ Hanging screen system (optional)
- 4 x 1.5 m / 13' x 5' single deck screen for recirculation back to feed conveyor, or stockpiling through 90° rotation of oversize conveyor to produce two products
 - Hydraulic operation from recirculating to stockpiling position