



MOBILE STOCKPILER
MPT 18g / 24g



CHASSIS	MPT 18g	MPT 24g
Weight [kg]	13800	15600
Dimension (length/width/height) [mm]	11862/2259/2557	11910/2259/2550

MATERIAL TRANSPORT	MPT 18g	MPT 24g
Efficiency max [t/h]	standard/opcja 500/600	standard/opcja 500/600
Max working angle of the stockpiler [°]	25,2	27,2
Max discharge height [mm]	8700	11300
Belt width [mm]	1000	1000
Belt length [mm]	18475	23000

ENGINE	MPT 18g	MPT 24g
Diesel engine	Caterpillar (EU Stage 3B, 3.4 l – 55,4 kW (75 KM) / 2200 rpm)	Caterpillar (EU Stage 3B, 3.4 l – 55,4 kW (75 KM) / 2200 rpm)

Mobile Stockpiler MPT 18g

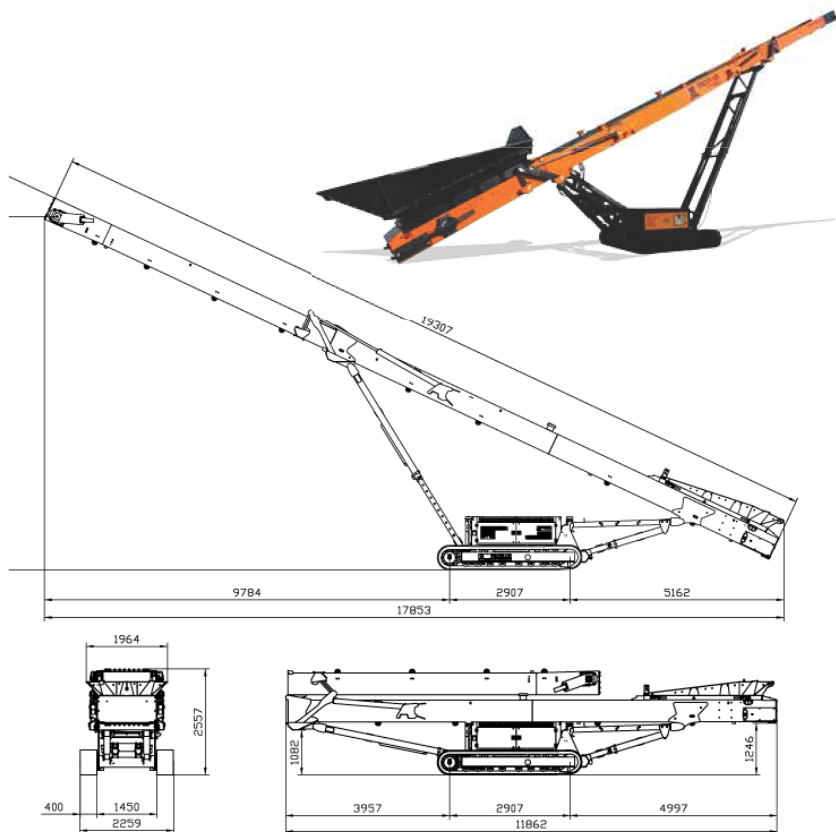

Mobile Stockpiler MPT 24g

